

FS-01D

1/10 SCALE RC 4WD FRONT MOTOR ELECTRIC DRIFT CAR

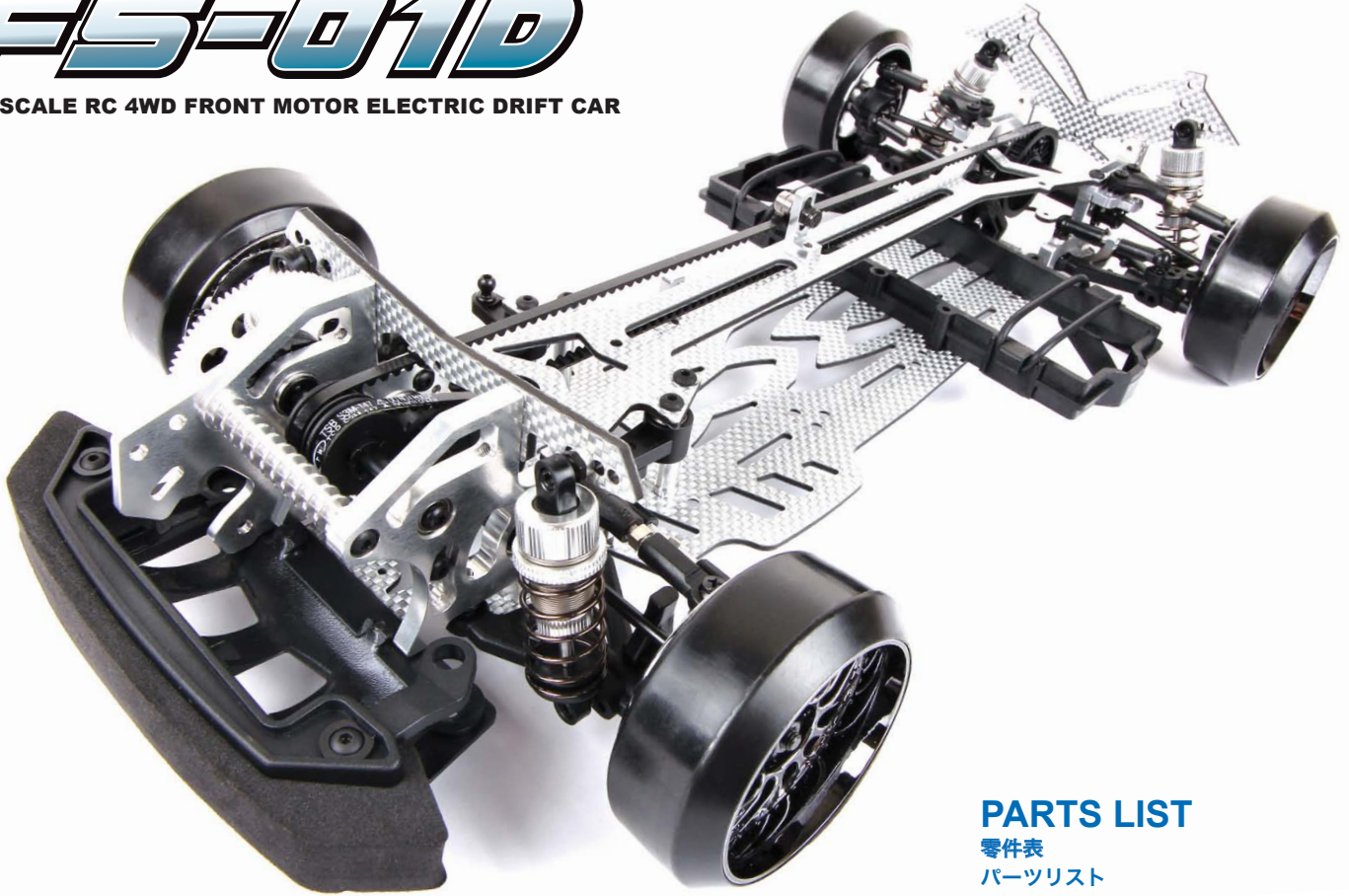

PARTS LIST

零件表
パーツリスト

※ Specifications are subject to change without notice.

PARTS CODE

























110001	Round head socket screw M3×6 (10)	120004	Thrust bearing 3×8	210104	Front ball diff unit	210193	Cross joint (4)
110002	Round head socket screw M3×8 (10)	120005	Ball bearing 3×6 (4)	210108S	Alum turn-buckle shaft 3×28mm (silver) (2)	210194	60deg universal shaft (2) (steel)
110003	Round head socket screw M2.5×6 (6)	120006	Ball bearing 3×7 (2)	210116S	Spur gear holder cover (silver)	210197	Carbon lower deck (SSG) w/ W rear brace
110005	Countersunk hex head screw M3×8 (10)	130001	O-ring 3.0 (10)	210132	4.8 ball connector (5)	210199	FS carbon front damper stay (SSG)
110007	Drub screw M3×6 (6)	130002	O-ring 11.5×1.5 (4)	210133	5.8 ball connector (5)	210200	Carbon rear damper stay (SSG)
110009	Drub screw M3×20 (6)	130003	O-ring 44×2.6 (2)	210134S	Alum upper bulkhead R/L (silver)	210201	FS carbon upper deck (SSG)
110010	Round head socket screw M2.5×14 (6)	130004	Oil seal (4)	210136S	Alum bulkhead R/L (silver)	210202	Carbon rear lower deck brace (W shape) (SSG)
110011	Cap screw M3×6 (6)	130006	Double sided tape (5)	210144-1	Coil spring 28mm (hard×2)	210203	FS carbon chassis set - 5pieces (SSG)
110012	Flat head screw M3×11(10)	130007	Antenna pipe (2)	210144-2	Coil spring 28mm (medium×2)	310001	Ball connector 4.8×4.5 (5)
110013	E-clip E2.0 (10)	130008	Black grease	210146	60deg universal shaft set (2)	310003S	Cylinder cap (silver) (2)
110014	Flat head screw M3×13(10)	130009	Damper oil #300	210147	Servo Saver Spring (hard) (black)	310004S	Spring retainer (silver) (2)
110015	Flage nut M4 (4)	130011	Tools	210151	Alum damper cylinder (4)	310005S	Rod guide cap (silver) (2)
110016	Snap pin R6 (10)	130016	FS bumper	210161	4.8mm ball connector nut (4)	310006	Wheel axle (2)
110017	Shaft 2×9.8 (10)	148082	MST 48P Spur Gear 82T	210162S	Alum belt pully mount (silver)	310008	Piston rod (2)
110018	Shaft 2×13.8 (5)	148083	MST 48P Spur Gear 83T	210165S	Alum turn-buckle shaft 3×20mm (silver) (2)	310014	Diff plate (2)
110019	Shaft 2×11.8 (5)	210002	C PARTS	210166S	Steel turn-buckle shaft 3×20mm (silver) (2)	310015	Diff screw & spring set
110020	3.0mm steel ball (13)	210004	E PARTS	210168S	Steel turn-buckle shaft 3×25mm (silver) (2)	310016	CVA universal shaft set
110021	Luck nut M3(5)	210005	F PARTS	210177S	Alum cooling bar (silver) (2)	310017S	Alum spacer 3×5.5×0.5 (silver)
110023	Drub screw M3×16 (6)	210007	H PARTS	210179S	FS alum bulkhead R/L (silver)	310018S	Alum spacer 3×5.5×1.0 (silver)
110024	Countersunk hex head screw M3×6 (10)	210008	I PARTS	210180S	FS alum upper arm mount (silver) (2)	310019S	Alum spacer 3×5.5×2.0 (silver)
110025	Taping screw 2.6×10(6)	210009	J PARTS	210181S	Alum post 17mm (silver) (2)	310020	Spacer 3x5x0.1mm (8)
110026	Round head socket screw M3×10 (10)	210010	K PARTS	210182S	Alum post 31.5mm (silver) (2)	310021	Spacer 3x5x0.3mm (8)
110029	Round head socket screw M3×12 (6)	210012	N PARTS	210183S	Alum steering post (silver) (2)	310025	Spacer 10x12x0.3mm (8)
110032	Drub screw M3×10 (6)	210014	O PARTS	210190	G PARTS	310026	FS direct center shaft
110037	E31-4.0 (10)	210016	R PARTS			414147	Drive belt-147
120001	Ball bearing 10×15 (4)	210017	S PARTS			414666	Drive belt-666
120002	Ball bearing 5×10 (4)	210018	Damper set				
120003	Ball bearing 5×8 (4)	210101S	Alum servo mount (silver)				

OPTION PARTS CODE









210102S	One way unit (silver)	210143	Alum wheel hubs (Brake disc shaped) (4)	210154-2	Coil spring 21mm (medium×2)	210205-1	DK Coil spring 30mm (Hard) (Silver) (2)
210103	One way joint (2)	210144	Coil spring set 28mm (8)	210154-3	Coil spring 21mm (soft×2)	210205-2	DK Coil spring 30mm (Medium) (Gold) (2)
210110	Stabilizer set	210144-3	Coil spring 28mm (soft×2)	210154-4	Coil spring 21mm (super soft×2)	210205-3	DK Coil spring 30mm (Soft) (Red) (2)
210113	Rear ball diff unit	210144-4	Coil spring 28mm (super soft×2)	210155	Servo saver spring (M)	210205-4	DK Coil spring 30mm (Super soft) (White) (2)
210115S	Alum damper set(4) (silver)	210145	Brake calipers (4)	210157S	Alum CVD universal shaft set (silver) (2)	210206	Alum Antenna Pipe Mount (Generalized)
210117S	Spur gear holder (silver)	210145R	Brake calipers-Red (4)	210159	5.8×4mm ball connector (4)	210207	Alum Pulley 10T
210118S	Alum upright (silver) (2)	210145B	Brake calipers-Blue (4)	210160	5.8×6mm ball connector (4)	210208	Alum Pulley 11T
210120S	Alum high torque servo saver (silver)	210145GD	Brake calipers-Glod (4)	210162S	Alum belt pulley mount (silver)	210209	Alum Pulley 12T
210121	Alum spool unit	210152	Piston (4)	210167S	Alum turn-buckle shaft 3×25mm (2)	210210	Alum Pulley 13T
210122S	Alum steering arm (silver)	210153	Rod guide set (4)	210184	FS CS pully set (1.54/1.66/1.82)	210211	Alum Pulley 18T
210123S	Alum belt stabilizer mount (silver)	210154	Coil spring set 21mm (8)	210196S	Alum stretch servo mount (silver)(2)	210212	Ball diff screw M3×26
210124	Alum belt pully	210154-1	Coil spring 21mm (hard×2)	210204S	Alum spool unit (silver)	414144	Drive belt-144
210137	4mm turnbuckle wrench			210205	DK Coil spring set 30mm		

PARTS

A PARTS



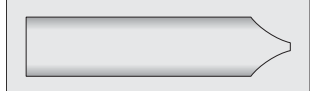
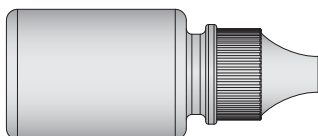
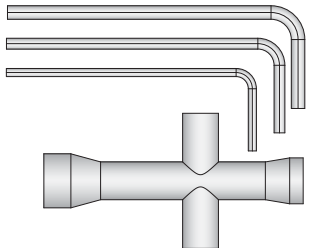

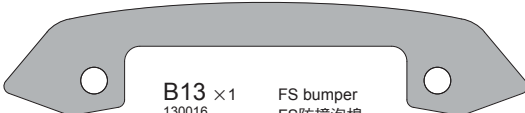

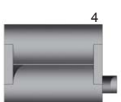
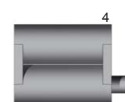

- | | | | | | | | |
|--|--------------------------|---------|-------------------------------|---|-------------------------|----------|-----------------------------------|
|  | A1 ×21
110001 | M3×6 | Screw
半圓頭螺絲
丸ビス |  | A14 ×4
110007 | M3×6 | Screw
止付螺絲
イモネジ |
|  | A2 ×16
110002 | M3×8 | Screw
半圓頭螺絲
丸ビス |  | A15 ×2
110032 | M3×10 | Screw
止付螺絲
イモネジ |
|  | A3 ×5
110026 | M3×10 | Screw
半圓頭螺絲
丸ビス |  | A16 ×3
110023 | M3×16 | Screw
止付螺絲
イモネジ |
|  | A4 ×1
110029 | M3×12 | Screw
半圓頭螺絲
丸ビス |  | A17 ×2
110009 | M3×20 | Screw
止付螺絲
イモネジ |
|  | A5 ×3
110003 | M2.5×6 | Screw
半圓頭螺絲
丸ビス |  | A18 ×6
110016 | R6 | R-clip
R形扣
スナップピン |
|  | A6 ×2
110010 | M2.5×14 | Screw
半圓頭螺絲
丸ビス |  | A19 ×8
110017 | 2×9.8mm | Shaft
插銷
シャフト |
|  | A7 ×1
110025 | M2.6×10 | Screw
半圓頭螺絲
丸ビス |  | A20 ×7
110019 | 2×11.8mm | Shaft
插銷
シャフト |
|  | A9 ×9
110014 | M3×13 | Screw
扁頭螺絲
フラットヘッドスクリュー |  | A21 ×1
110018 | 2×13.8mm | Shaft
插銷
シャフト |
|  | A10 ×16
110012 | M3×11 | Screw
扁頭螺絲
フラットヘッドスクリュー |  | A22 ×2
110021 | M3 | Lock nut
防鬆螺帽
ロックナット |
|  | A11 ×4
110041 | M3×5 | Screw
沉頭螺絲
皿ビス |  | A23 ×4
110015 | M4 | Flange nut
凸緣螺帽
フランジロックナット |
|  | A12 ×4
110024 | M3×6 | Screw
沉頭螺絲
皿ビス |  | A24 ×3
110037 | 4.0 | E-clip
E形扣
Eリング |
|  | A13 ×19
110005 | M3×8 | Screw
沉頭螺絲
皿ビス |  | A25 ×2
110011 | M3×6 | Screw
有頭螺絲
キャップスクリュー |
| | | | |  | A26 ×1
310015 | M3×25 | Diff screw
滾差螺絲
デフキャップスクリュー |

B PARTS

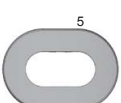
- | | | | | | | | |
|--|-------------------------|----------|---|--|-------------------------|--------|----------------------------------|
|  | B1 ×8
120001 | 10×15mm | Ball bearing
滾珠軸承
ボールベアリング |  | B2 ×7
120002 | 5×10mm | Ball bearing
滾珠軸承
ボールベアリング |
|  | B3 ×4
120003 | 5×8mm | Ball bearing
滾珠軸承
ボールベアリング |  | B4 ×2
120005 | 3×6mm | Ball bearing
滾珠軸承
ボールベアリング |
|  | B5 ×1
120004 | 3×8mm | Thrust bearing
止推軸承
スラストベアリング |  | B6 ×2
120006 | 3×7mm | Ball bearing
滾珠軸承
ボールベアリング |
|  | B7 ×1
130006 | | Double side tape
泡棉雙面膠
スポンジ両面テープ |  | B8 ×1
130008 | | Black grease
黑色油膏
クリス |
|  | B9 ×1
130009 | | Damper oil 300#
避震油 300#
ダンパーオイル 300# |  | B10 ×1
130011 | | Tools
工具包
工具セット |
|  | B11 ×2
130003 | 44×2.6mm | O-ring
O形環
Oリング |  | B12 ×1
130007 | | Antenna pipe
天線管
アンテナパイプ |
|  | B13 ×1
130016 | | FS bumper
FS防撞泡棉
FSバンパー | | | | |

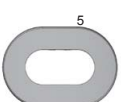
C PARTS

210002

- | | | | | | |
|--|---|---|---|---|---|
|  | 2 |  | 4 |  | 4 |
|  | 2 |  | 5 |  | 5 |
|  | 3 |  | 5 |  | 5 |
|  | 3 |  | 1 | | |

PARTS

D PARTS

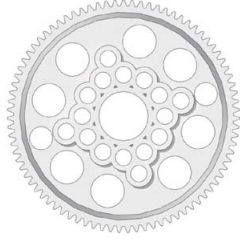

D1 ×1
Spur gear
大齒盤
スパーギヤ

D3 ×1
414666
Drive belt (666)
皮帶 (666)
ドライブベルト (666)

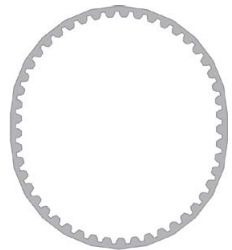

D2 ×1
414147
Drive belt (147)
皮帶 (147)
ドライブベルト (147)

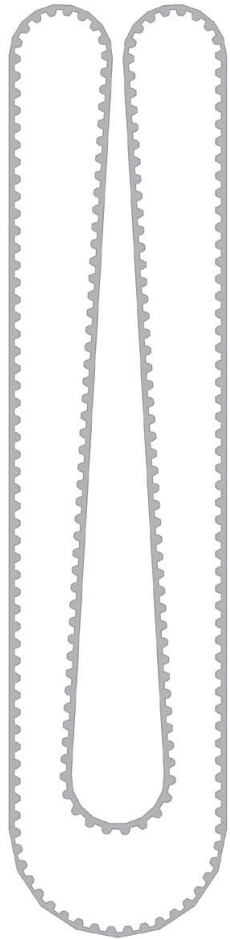

E PARTS

210004

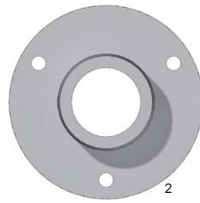

2

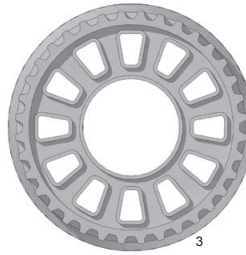

3



4



5



6



6



7



8



1

G PARTS ×4

210190



1

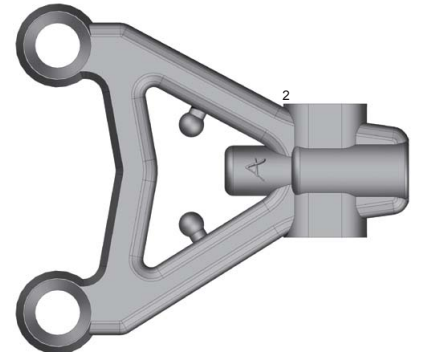

2



3



3

F PARTS



F1 ×4
210005
Damper cap
避震器上球座
ダンパーキャップ



F6 ×4
310003S
Cylinder cap
避震器上蓋
シリンダーキャップ



F11 ×4
130001
3mm O-ring
O形環
Oリング



F13 ×4
210151
Alum damper cylinder
鋁合金避震器筒身
アルミ製 ダンパーシリンダー



F2 ×4
310004S
Spring retainer
避震器調整環
スプリングリテーナー



F7 ×4
210005
Piston
避震活塞
ピストン



F12 ×8
110013
2.0 E-clip
E形扣
Eリング



F15 ×4
130002
11.5 × 1.5mm O-ring
O形環
Oリング



F3 ×4
210005
Shaft guide
O環墊片
シャフトガイド



F8 ×4
130004
Oil seal
避震氣室
オイルシール



F14 ×4
310008
Piston rod
避震軸心
ピストンロッド



F16 ×2
210144-1
Coil spring 28mm (stiff)
避震彈簧28mm (硬)
コイルスプリング28mm (ハード)



F17 ×2
210144-2
Coil spring 28mm (medium)
避震彈簧28mm (中)
コイルスプリング28mm (ミディアム)



F4 ×4
210005
Rod guide
下蓋墊片
ロッドガイド



F9 ×4
210005
Damper adjuster
避震器下拉桿頭
ダンパーアジャスター



F5 ×4
210005
Damper retainer
避震器下座
ダンパーリテーナー



F10 ×4
310005S
Rod guide cap
避震器下蓋
ロッドガイドキャップ

H PARTS ×2

210007

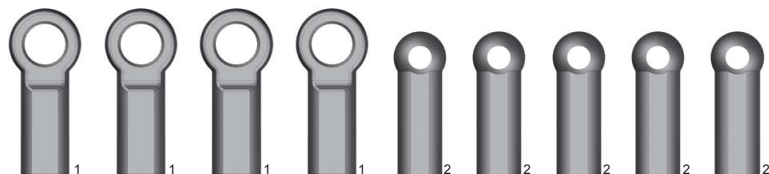

I PARTS ×2

210008

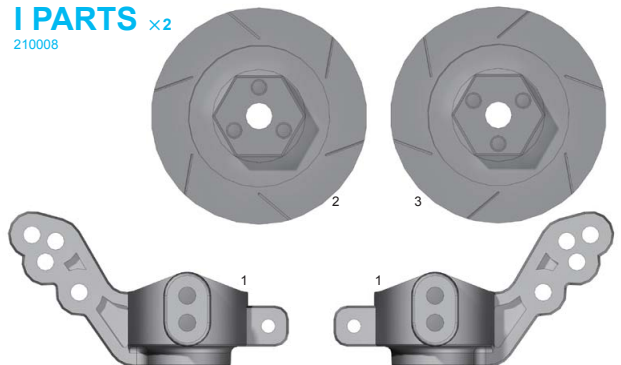

PARTS

L PARTS

210104

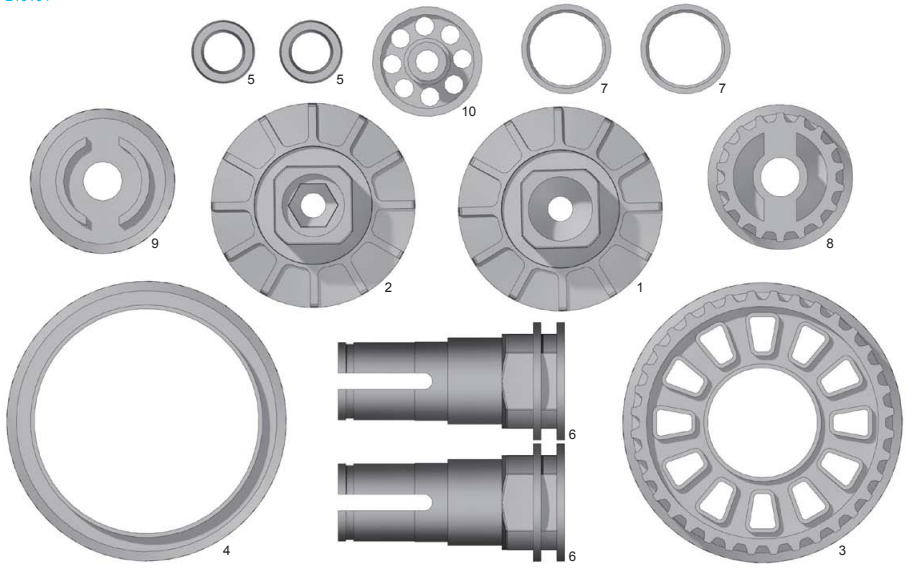

O PARTS

210014

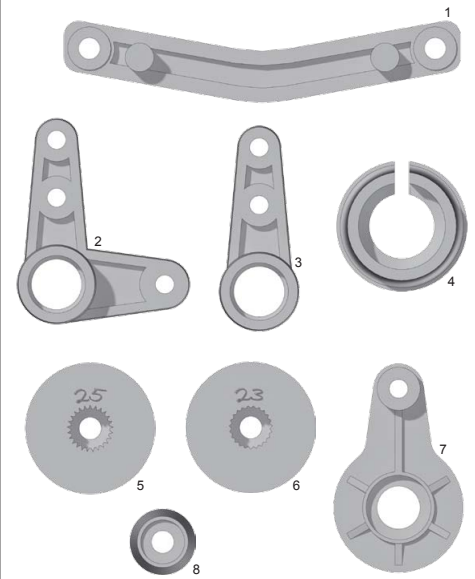

N PARTS

N1 × 1
210012
Battery mount set
電池座
バッテリーマウント

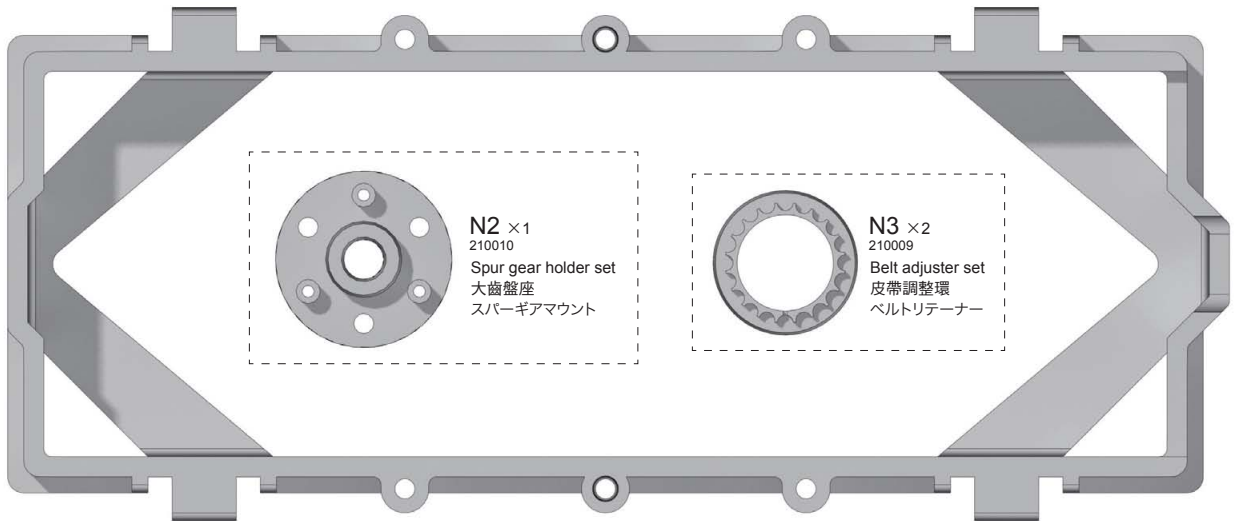

N2 × 1
210010
Spur gear holder set
大齒盤座
スパーギアマウント

N3 × 2
210009
Belt adjuster set
皮帶調整環
ベルトリテーナー

Q PARTS

Q1 × 1
210136S
Alum bulkhead
鋁合金側板組
アルミ製 バルクヘッド

Q2 × 1
210136S
Alum bulkhead
鋁合金側板組
アルミ製 バルクヘッド

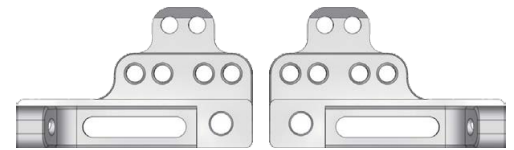

Q3 × 1
210134S
Alum upper bulkhead
鋁合金側板上蓋組
アルミ製 アッパーバルクヘッド

Q4 × 1
210134S
Alum upper bulkhead
鋁合金側板上蓋組
アルミ製 アッパーバルクヘッド

Q7 × 2
210101S
Alum servo mount
鋁合金伺服機座
アルミ製 サーボマウント

Q8 × 1
210162S
Alum belt pulley mount
鋁合金皮帶壓輪座
アルミ製プーリーマウント

Q9 × 2
210180S
FS Alum upper arm mount
FS鋁合金擺臂座
FSアルミ製
アッパーアームマウント

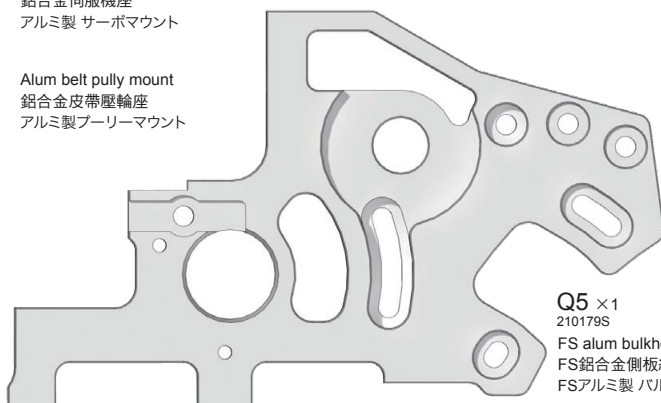

Q5 × 1
210179S
FS alum bulkhead
FS鋁合金側板組
FSアルミ製 バルクヘッド

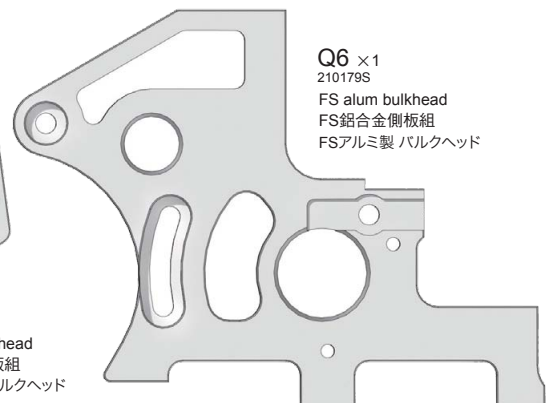

Q6 × 1
210179S
FS alum bulkhead
FS鋁合金側板組
FSアルミ製 バルクヘッド

PARTS

P PARTS

<p>P1 ×12 310001 4.8×4.5mm Ball connector 球頭 ビロボール</p>	<p>P10 ×16 210133 5.8mm Ball connector 金屬球頭 スチールビロボール</p>	<p>P11 ×8 210132 4.8mm Ball connector 金屬球頭 スチールビロボール</p>	<p>P18 ×6 210161 4.8mm Ball connector nut 外六角球頭螺帽 ビロボールナット</p>
<p>P2 ×1 310026 FS direct center shaft FS主齒軸 FSセンターシャフト</p>	<p>P12 ×2 310018S 3×5.5×1mm Spacer 調整墊片 スペーサ</p>	<p>P13 ×4 310019S 3×5.5×2mm Spacer 調整墊片 スペーサ</p>	<p>P14 ×3 310017S 3×5.5×0.5mm Spacer 調整墊片 スペーサ</p>
<p>P3 ×4 310006 Wheel axle 萬向接杯 ホイールアクスル</p>	<p>P15 ×3 310021 3×5×0.3mm Spacer 調整墊片 スペーサ</p>	<p>P16 ×2 310020 3×5×0.1mm Spacer 調整墊片 スペーサ</p>	<p>P20 ×2 210181S Alum post 17mm 鋁合金支柱17mm アルミ製ポスト17mm</p>
<p>P4 ×2 310007 CVA swing shaft CVA傳動軸 CVAスイングシャフト</p>	<p>P17 ×1 310025 10×12×0.3mm Spacer 調整墊片 スペーサ</p>	<p>P19 ×1 210116S Alum spur gear holder cover 鋁合金主齒固定板 アルミ製 スパーギア ホルダーカバー</p>	<p>P21 ×2 210182S Alum post 31.5mm 鋁合金支柱 31.5mm アルミ製 ポスト 31.5mm</p>
<p>P5 ×2 210194 CVD swing shaft CVD傳動軸 CVDスイングシャフト</p>	<p>P22 ×1 210177S Alum heat sink bar 鋁合金散熱柱 アルミ製 ヒートシンクバー</p>	<p>P23 ×2 210165S Alum turn-buckle shaft 3×20mm 鋁製可調拉桿 3×20mm スチールターンバックルシャフト 3×20mm</p>	<p>P27 ×1 310015 Diff spring 滾差彈簧 デフスプリング</p>
<p>P6 ×2 210193 Cross joint 連接軸 クロスバイダー</p>	<p>P25 ×2 210166S Steel turn-buckle shaft 3×20mm 鋼製可調拉桿 3×20mm スチール ターンバックルシャフト 3×20mm</p>	<p>P28 ×1 210147 Servo saver spring (H) 緩衝器簧圈 (硬) サーボセイバースプリング (ハード)</p>	<p>P29 ×12 110020 3mm Steel ball 鋼珠 スチールボール</p>
<p>P7 ×2 210183S Alum steering post 轉向支柱 アルミ製 ステアリングポスト</p>	<p>P24 ×3 210108S Alum turn-buckle shaft 3×28mm 鋁製可調拉桿 3×28mm アルミ製 ターンバックルシャフト 3×28mm</p>	<p>P26 ×2 210168S Steel turn-buckle shaft 3×25mm 鋼製可調拉桿 3×25mm スチール ターンバックルシャフト 3×25mm</p>	
<p>P8 ×1 210185 Inner pulley holder 皮帶輪保持器 プーリーホルダー</p>	<p>P9 ×2 310014 Diff plate 滾差壓板 デフプレート</p>		

R PARTS

210016



1 2 3 4

S PARTS

210017



1 2

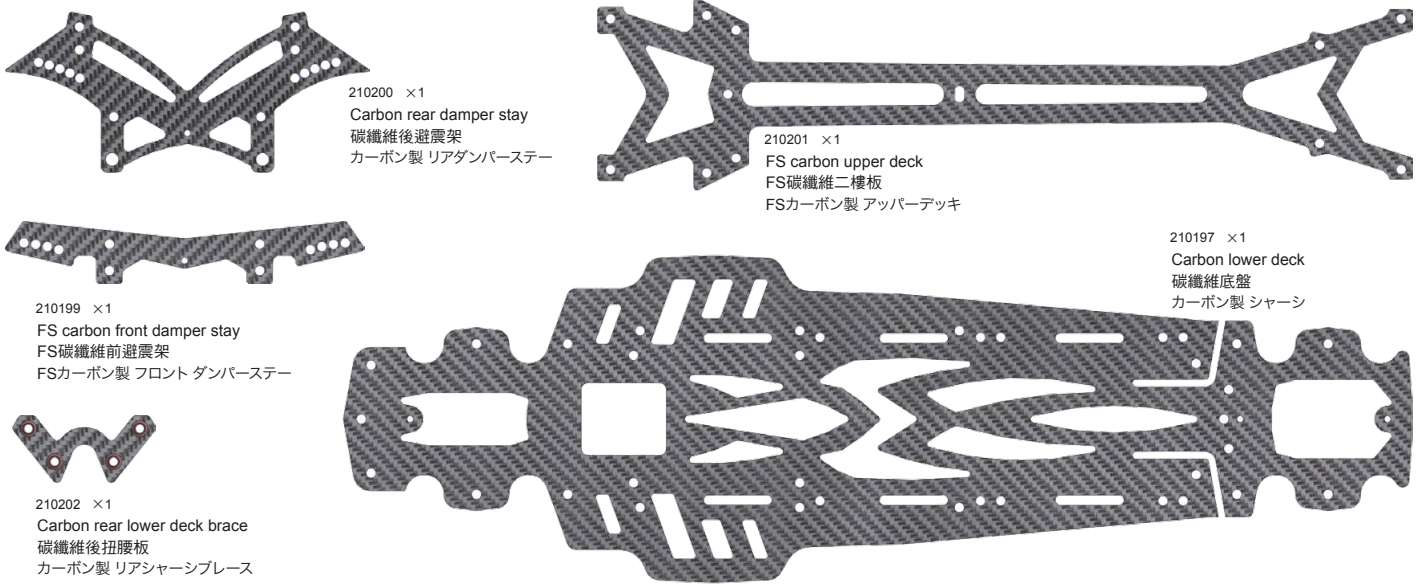

210200 ×1
Carbon rear damper stay
碳纖維後避震架
カーボン製 リアダンパーステア

210201 ×1
FS carbon upper deck
FS碳纖維上樓板
FSカーボン製 アッパーデッキ

210199 ×1
FS carbon front damper stay
FS碳纖維前避震架
FSカーボン製 フロント ダンパーステア

210202 ×1
Carbon rear lower deck brace
碳纖維後扭腰板
カーボン製 リアシャーシブレース

210197 ×1
Carbon lower deck
碳纖維底盤
カーボン製 シャーシ

部品編號

Table with 4 columns: Part Number, Description, Part Number, Description, Part Number, Description. Lists various components like screws, bearings, and springs.

改装品編號

Table with 4 columns: Part Number, Description, Part Number, Description, Part Number, Description. Lists modified parts like shock absorbers, springs, and dampers.

パーツリスト (零件清單)

Table with 4 columns: Part Number, Description, Part Number, Description, Part Number, Description. Lists standard parts like bearings, O-rings, and shafts.

オプションパーツリスト (改装品清單)

Table with 4 columns: Part Number, Description, Part Number, Description, Part Number, Description. Lists optional parts like shock absorbers, springs, and dampers.

